



BEST

Bioenergy and
Sustainable Technologies



 Bundesministerium
Innovation, Mobilität
und Infrastruktur

 Bundesministerium
Wirtschaft, Energie
und Tourismus



 Für die
Stadt Wien





Pyrolysis of biogenic feedstocks and biochar production at the GreenCarbonLab

Wieselburg, 23. September 2025

Manuel Schwabl, Elisabeth Wopienka



 Bundesministerium
Innovation, Mobilität
und Infrastruktur

 Bundesministerium
Wirtschaft, Energie
und Tourismus



 Für die
Stadt Wien



GreenCarbon-Lab – from lab to pilot

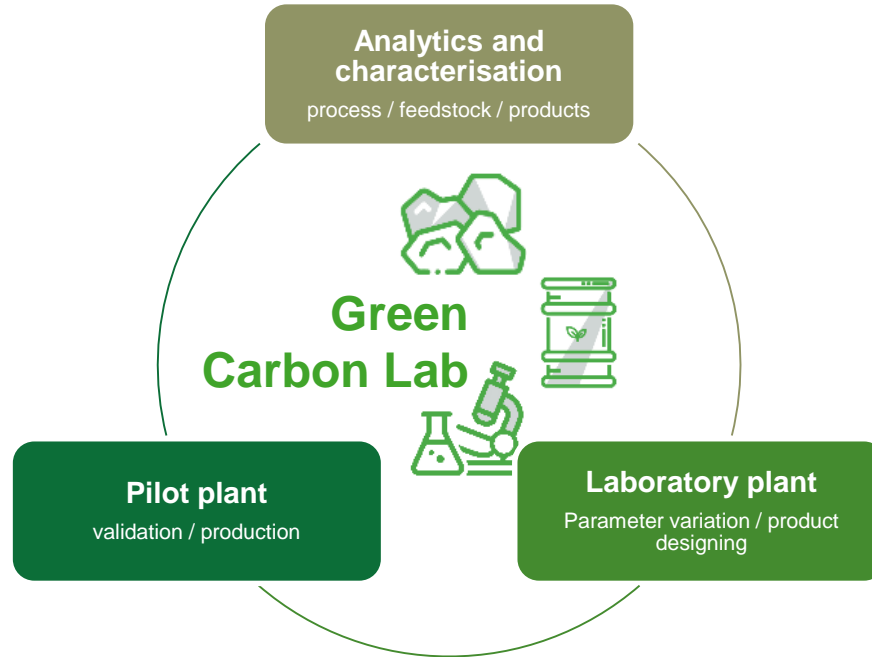

GreenCarbon-Lab - from lab to pilot

Method	Fuel input / capacity	Information – output
Thermogravimetric analysis + Steam-TGA, + FT-IR- coupling	50 mg	Reaction kinetics
Single Particle Reactor	3 g 1 pellet / particle	Influence of temperatur, atmosphere on conversion chracteristics
flex200 Muffle furnace	200 g	Batch operation
flex400 Laboratory-reaktor	250 g – 400 g	Fuel bed / bulk
pyro2k Pyrolysis unit – lab scale	2kg/h ~ 20 kW	Raw material-Tests (stationary), parameter-study (residence time, temperature, throughput, ...), product design
pyro90k Pyrolysis unit – pilot scale	90 kg/h ~ 150 kW	Validation of lab tests, production of test batches

GreenCarbon Lab – flex400 pyrolysis – gasification - combustion

Batch reactor

- up to 400g feedstock
- 1000 °C
- heating rate up to 20°C/min
- variable gas atmosphere

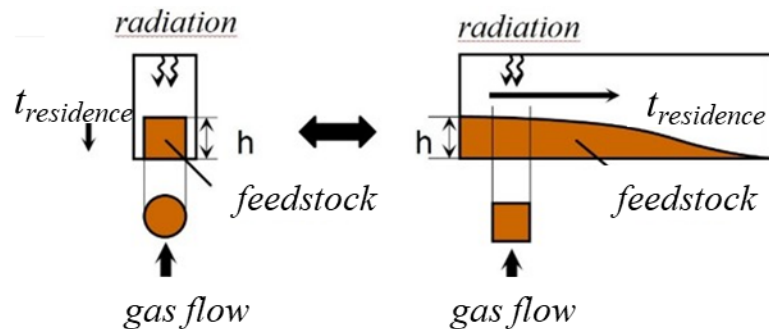
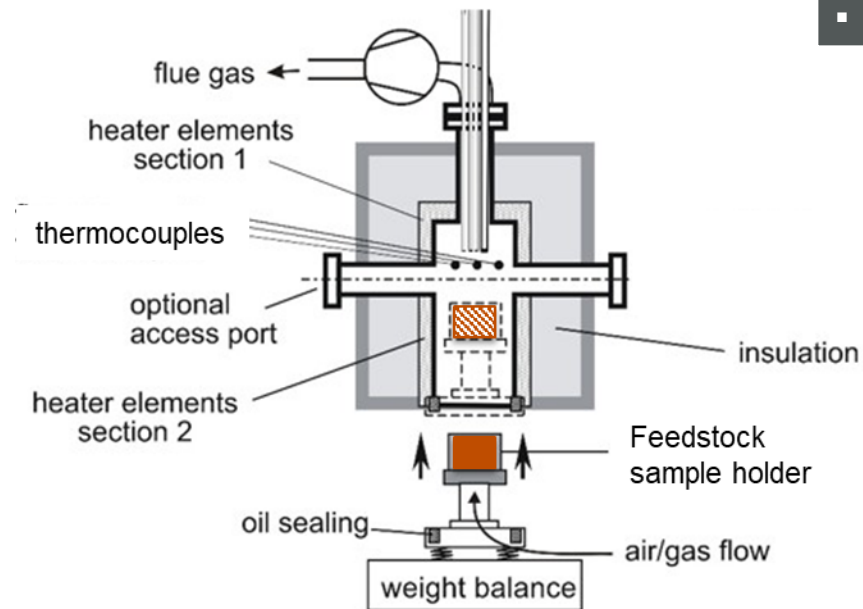

GreenCarbon Lab – flex400 pyrolysis – gasification - combustion

Batch reactor

- up to 400g feedstock
- 1000 °C
- heating rate up to 20°C/min
- variable gas atmosphere

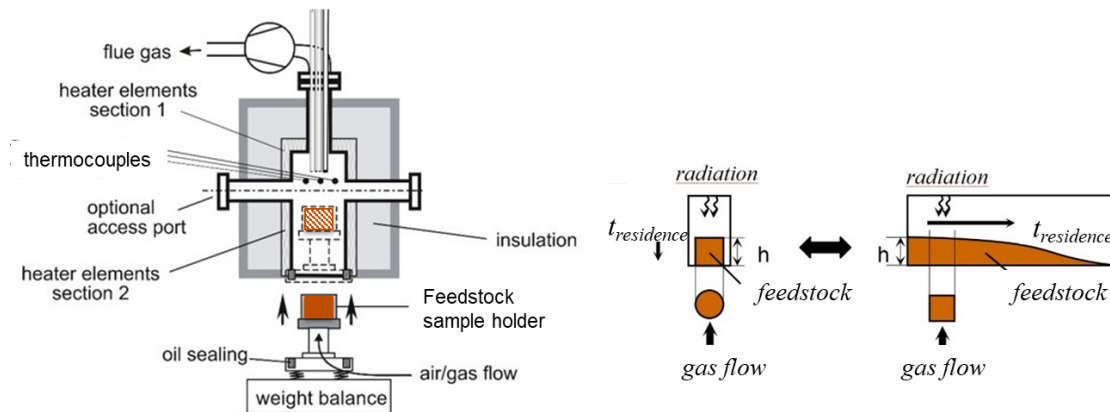

feedstock behaviour – first product samples – process innovation tests

GreenCarbon Lab – pyro2k

Rotary kiln – lab-scale

- 2 kg/h feedstock input
- 3 temperature zones
- 200° - 1000°C
- Variable residence time (10-60mins)
- Defined gas atmosphere

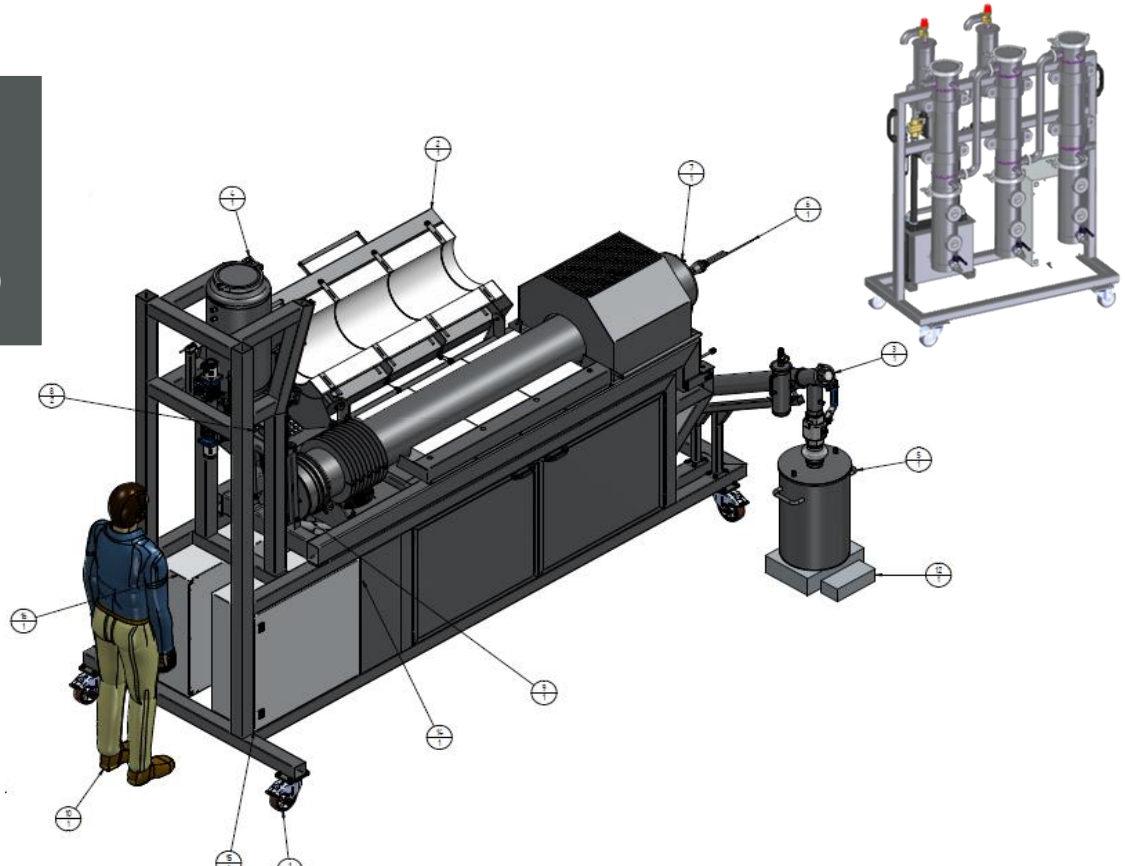

GreenCarbon Lab – pyro2k



Europäische Union



Investitionen in Wachstum & Beschäftigung. Österreich.



Rotary kiln – lab-scale

- 2 kg/h feedstock input
- 3 temperature zones
- 200° - 1000°C
- Variable residence time (10-60mins)
- Defined gas atmosphere

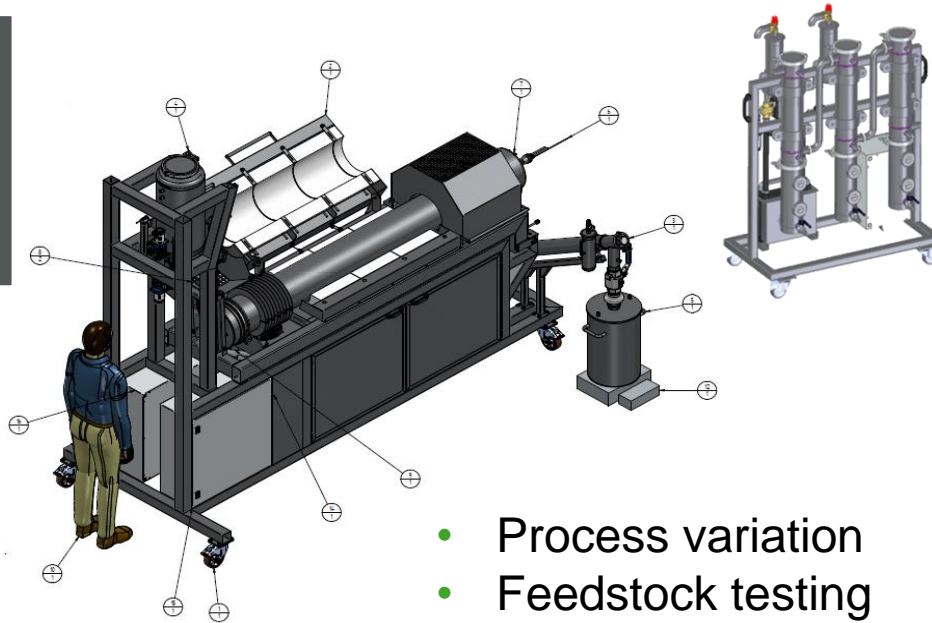

- Process variation
- Feedstock testing
- Product sample production
- Mass- and energy balances

GreenCarbon Lab – pyro 90k



Europäische Union



Investitionen in Wachstum & Beschäftigung. Österreich.



double-auger – pilot-scale

- 90kg/h input
- 25 – 30 kg char /h
- 3 temperature zones
- 300° - 800°C
- Defined process conditions
- Direct combustion of pyrolysis gases

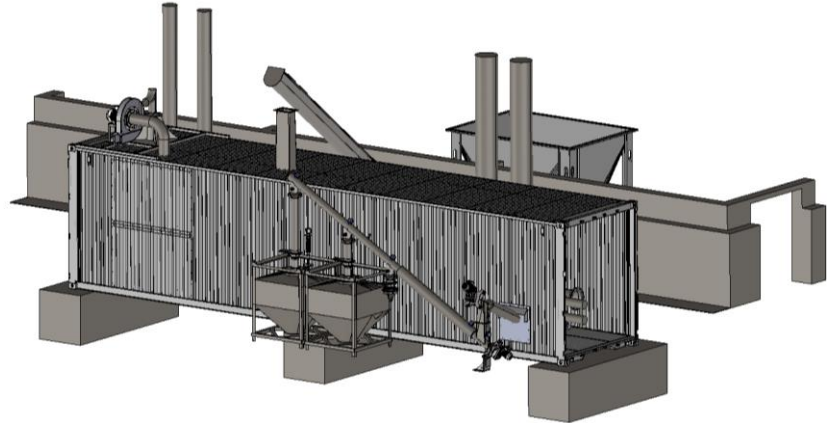

GreenCarbon Lab – pyro 90k



Europäische Union



Investitionen in Wachstum & Beschäftigung. Österreich.



- validation of biochar-„recipes“
- Pilot testing for biochar applications
- Long-term tests (24/7)
 - deposits
 - corrosion



double-auger – pilot-scale

- 90kg/h input
- 25 – 30 kg char /h
- 3 temperature zones
- 300° - 800°C
- Defined process conditions
- Direct combustion of pyrolysis gases

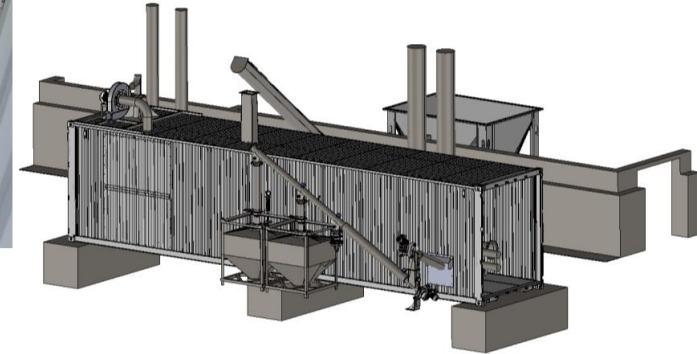

GreenCarbon Lab – Feedstock-tests



Spruce pellets



Wood chips



Coffee husks



Poplar pellets



Walnut shells



**Compost screening
overflow**



Sunflower kernel



**Sunflower kernel
husks**



Tobacco stalks



Wheat bran

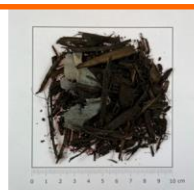

**Compost screening
overflow**



Sunflower kernel



**Sunflower kernel
husks**



Tobacco stalks



Wheat bran



**Compost screening
overflow**



Sunflower kernel



**Sunflower kernel
husks**



Tobacco stalks



Wheat bran

just started!

GreenCarbon Lab – pyrolysis temperature impact

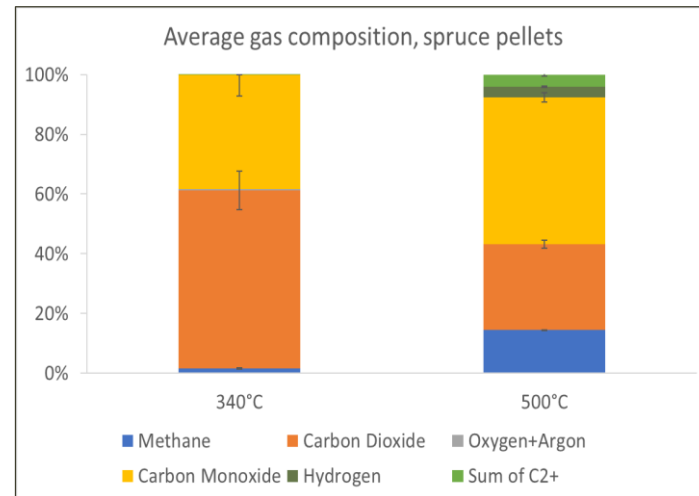
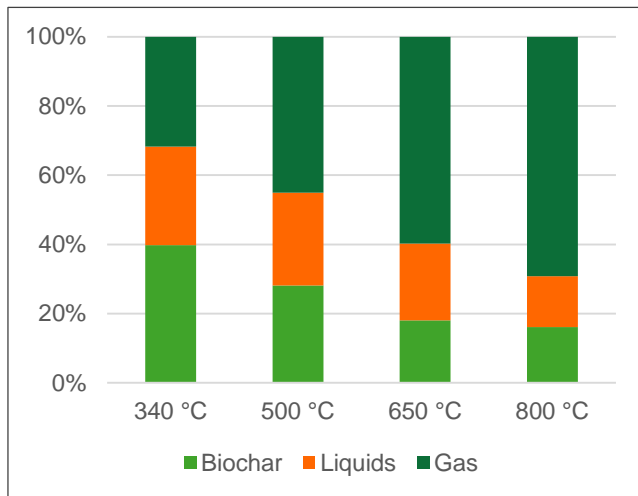

Product quality
Product yields
Energy efficiency

GreenCarbon Lab – pyrolysis liquids

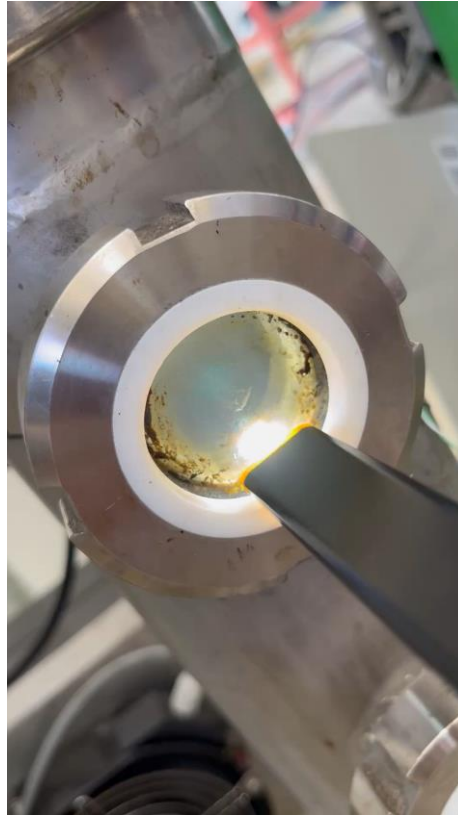

ESP **on**....

ESP **off**....

GreenCarbon Lab – pyrolysis liquids

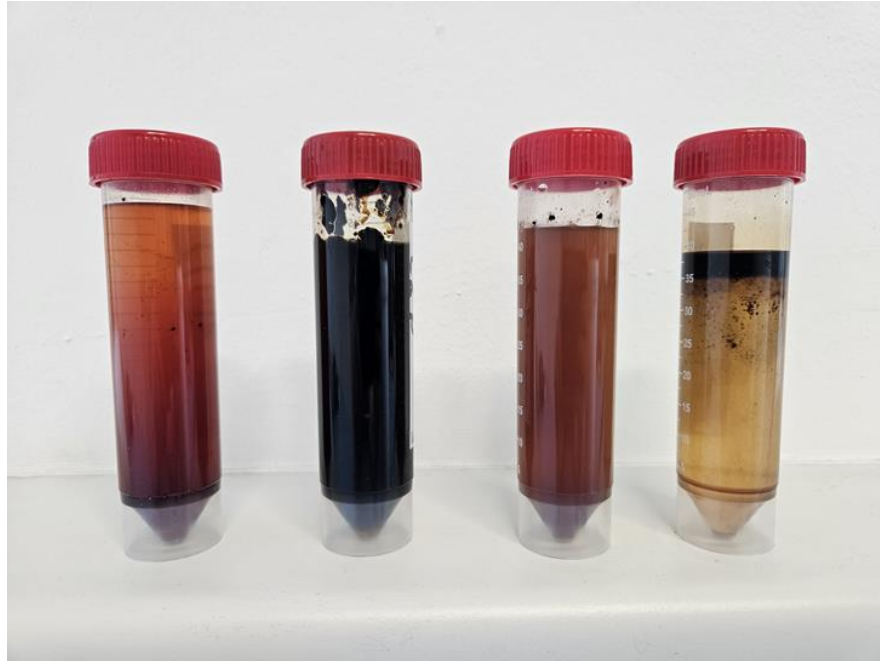
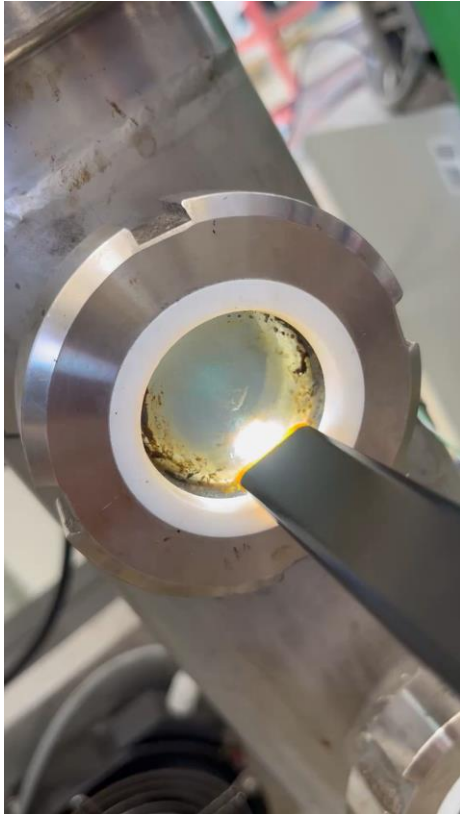

... up to 7% of feedstock input!

Conclusions

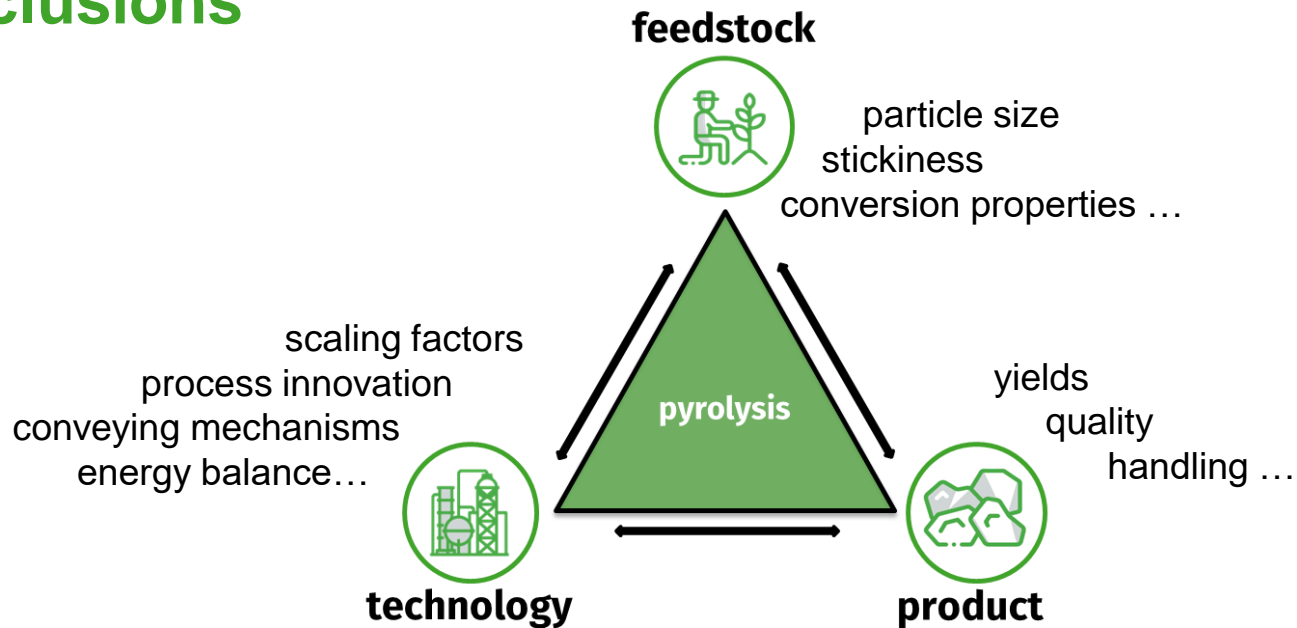

... any Questions?



Manuel Schwabl

manuel.schwabl@best-research.eu

+43 5 02378 9441

Elisabeth Wopienka

elisabeth.wopienka@best-research.eu

+43 5 02378 9438